

# Short and Tall

Identify the tallest item by coloring it.

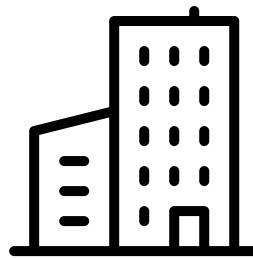
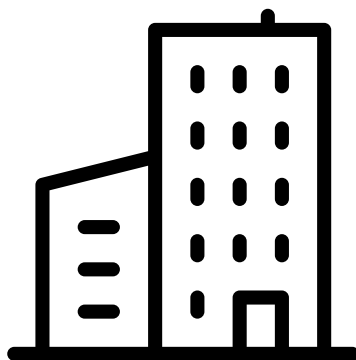
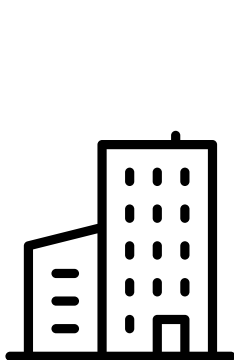
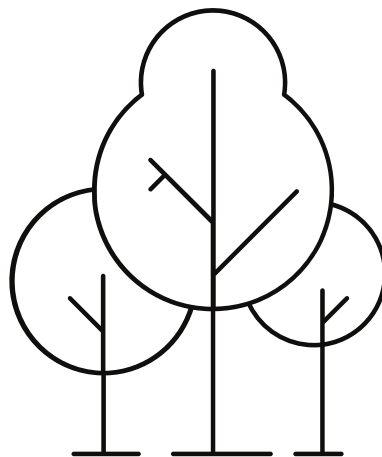
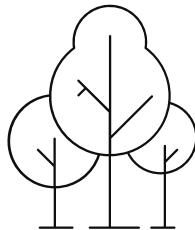
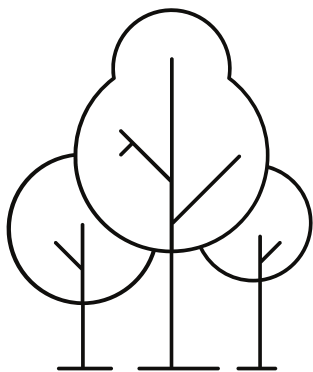

# Tall and Short

Observe the given sets of picture. Circle the one that is taller in each set.

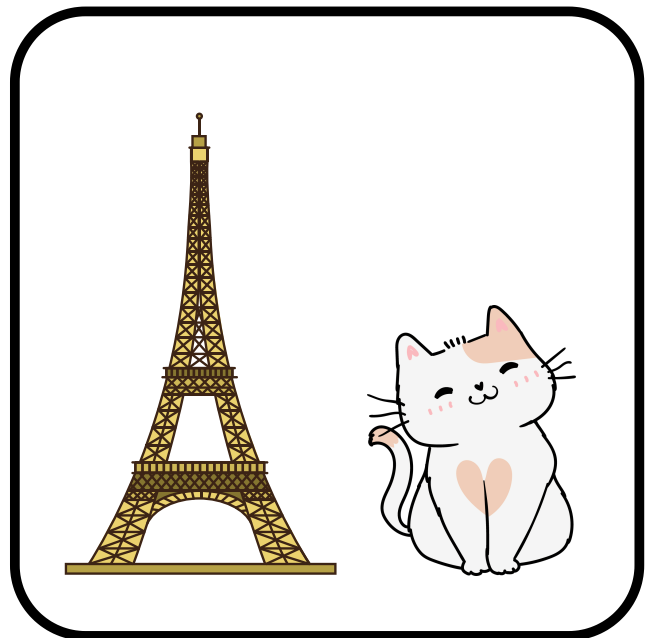
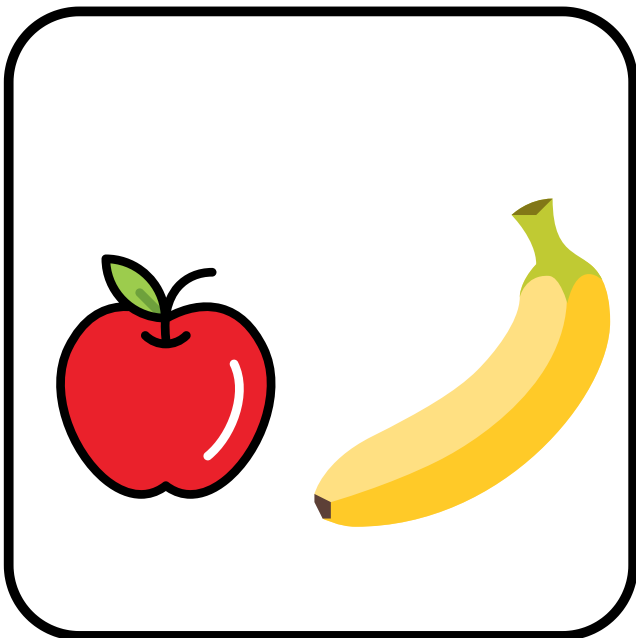
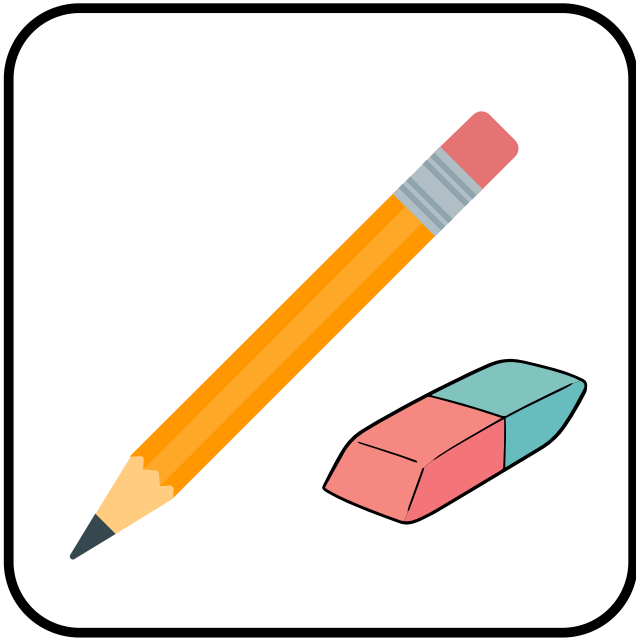

# Tall and Short

Identify the pictures below. Circle the tall picture.

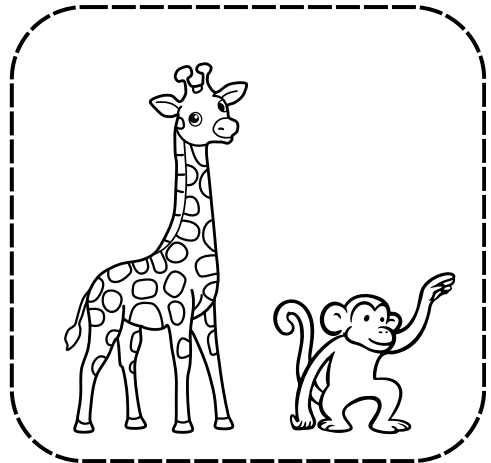
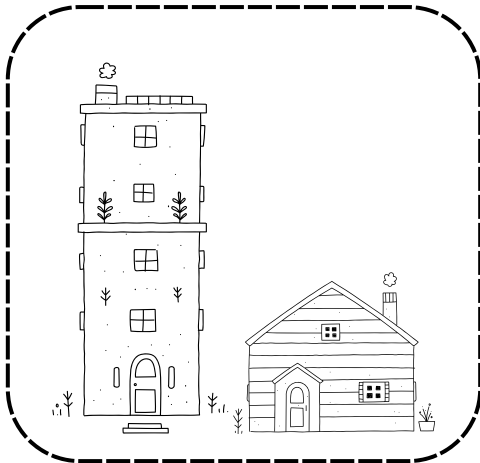
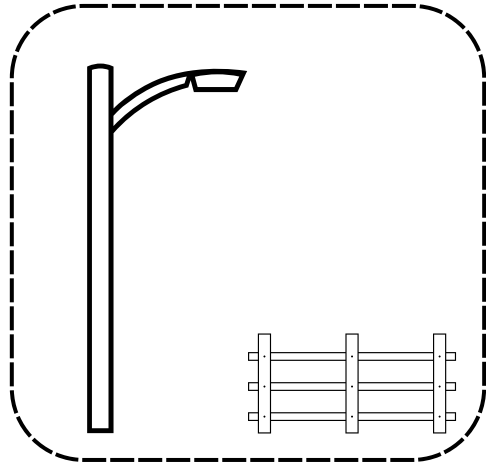
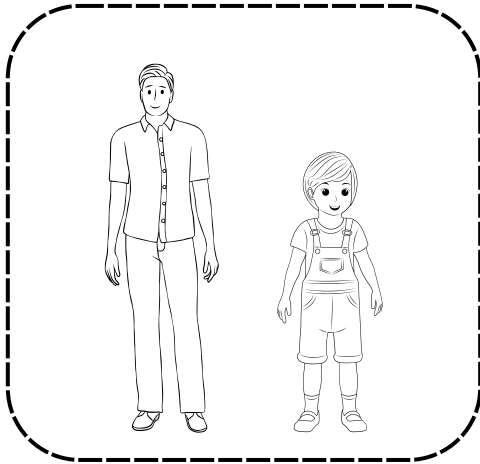

# LONG OR SHORT

Circle the shortest and colour the longest.

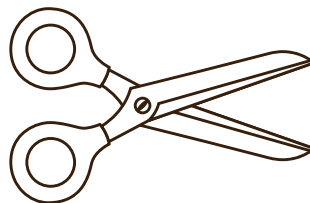
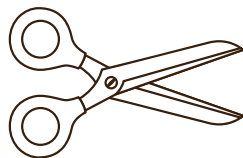
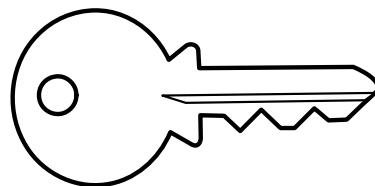
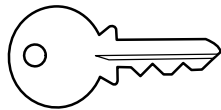
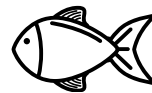
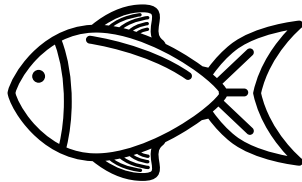
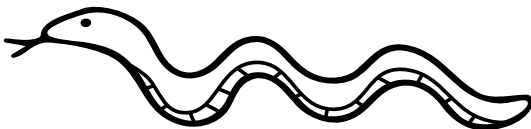
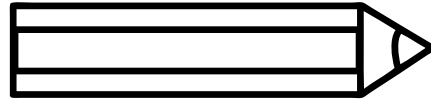
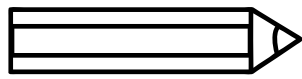

# WHICH ONE IS TALLER?

Tick the taller animal and cross out the smaller object in each circle below the pictures.

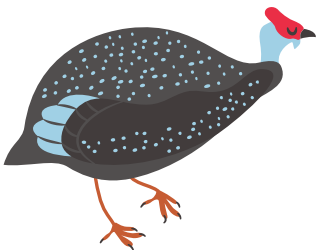

# TALLEST AMONG THEM ALL

circle and color the tallest one in the row.

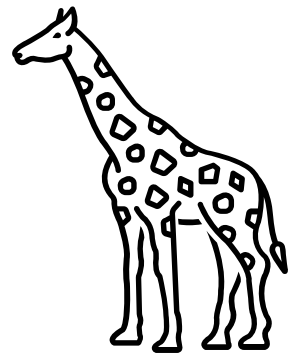
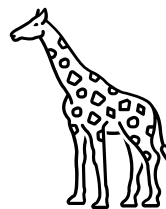
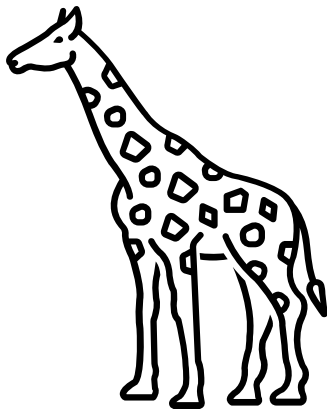
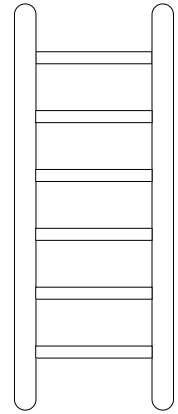
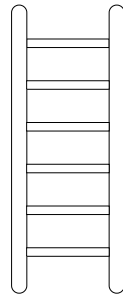
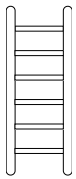
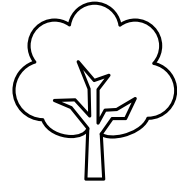
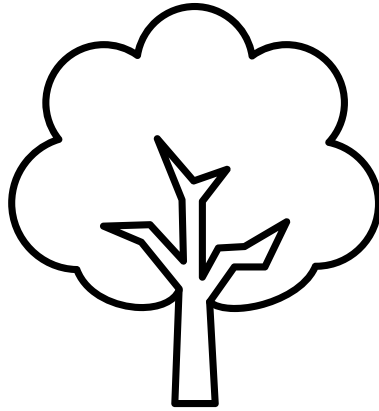
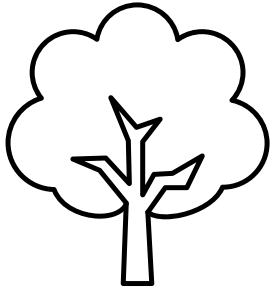

# TALL OR SHORT

Circle the tallest and colour the shortest.

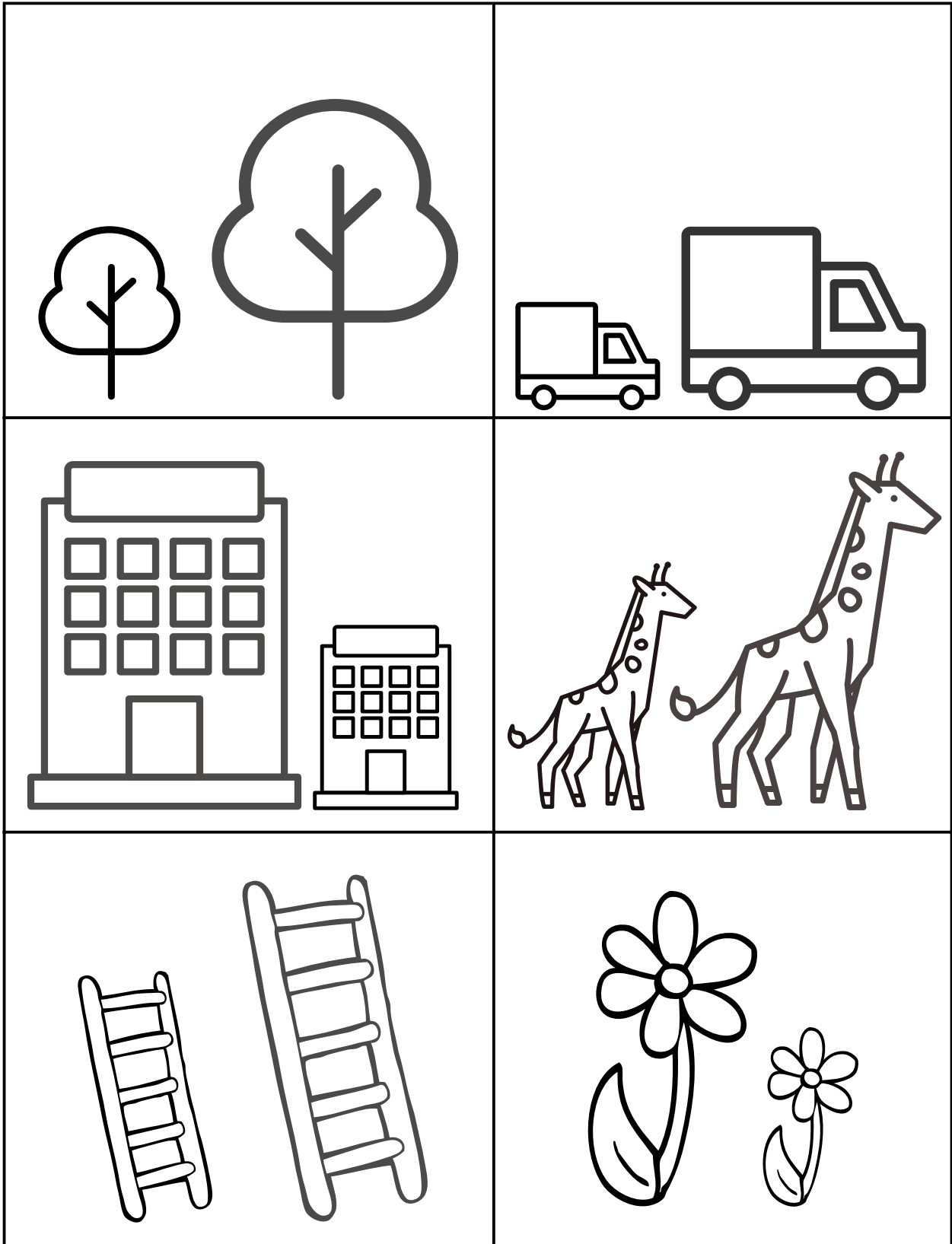

# Comparing Length

Color the correct answer.

Which snake is shorter?

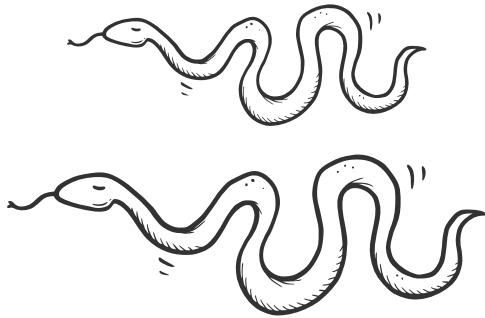

Which pencil is longer?

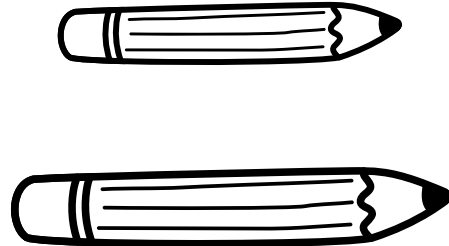

Which banana is shorter?

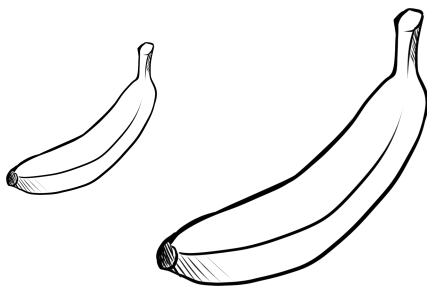

Which stick is longer?

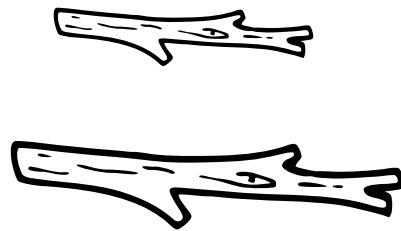

Which car is shorter?



Which ruler is longer?

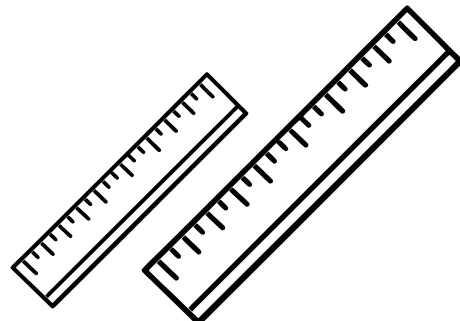

# Height Measurement

Color the number of blocks to measure the animal's height and write the number in the circle.

